

Heavy-Current Terminals

750 and 1125 Series.

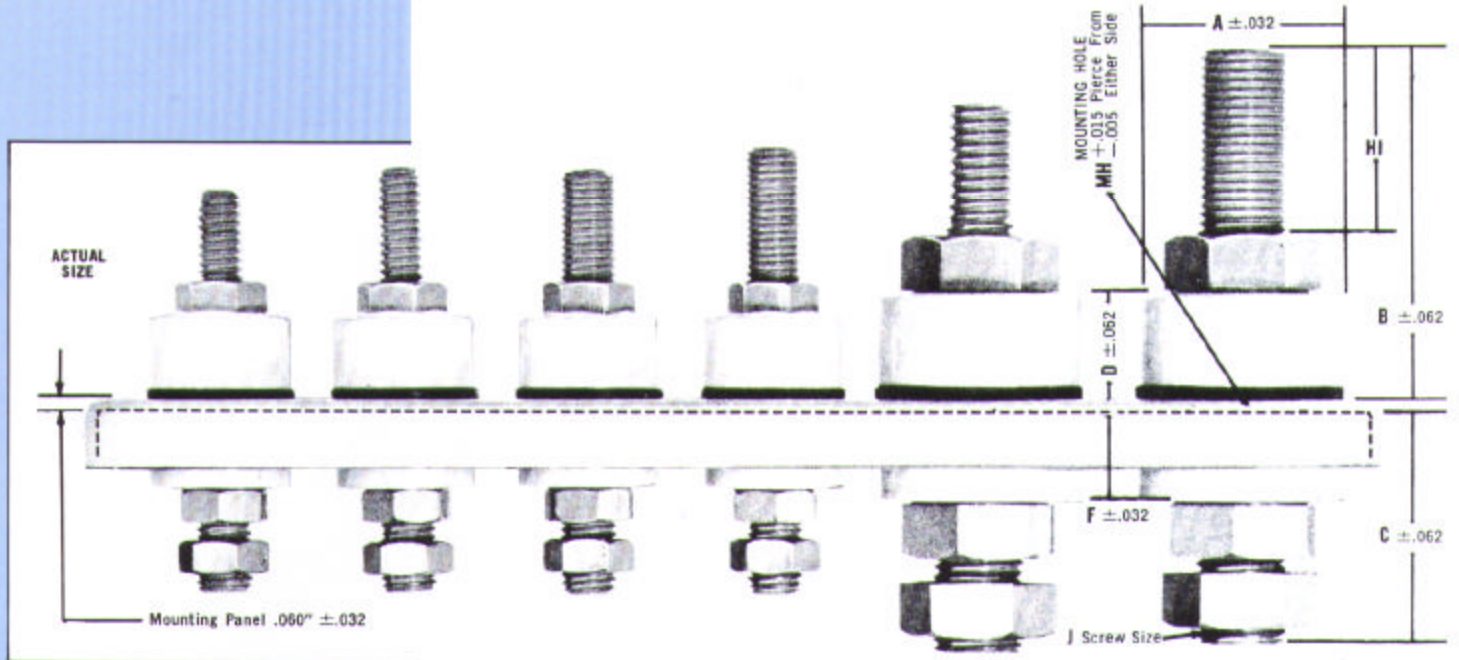

	750 -HC16- 152J	750 -HC20- 152J	750 -HC20- 152K	750 -HC24- 152K	1125 -HC24- 152N	1125 -HC32- 152P	
A	3/4	3/4	3/4	3/4	1-1/8	1-1/8	A
B	1-1/8	1-1/4	1-1/4	1-3/8	1-5/8	1-7/8	B
C	1	1	1	1	1-3/8	1-3/8	C
D	7/16	7/16	7/16	7/16	9/16	9/16	D
F	7/16	7/16	7/16	7/16	1/2	1/2	F
H	1/4-20	1/4-20	5/16-24	5/16-24	3/8-16	1/2-20	H
HI	1/2	5/8	5/8	3/4	3/4	1	HI
J	5/16-24	5/16-24	5/16-24	5/16-24	1/2-20	1/2-20	J
MH	.500	.500	.500	.500	.750	.750	MH
TEST	6000	6000	6000	6000	9000	9000	TEST
AMP	25	25	50	50	80	150	AMP

CURRENT RATING is equal to 1000 Amps. per square inch of brass area for thread minor diameter.
COPPER CONDUCTORS available to order.

HEX NUTS are supplied with counterbore providing recess for solder.

SECOND NUT is supplied to hold heavy current lug or wire as illustrated. First nut should be soldered to conductor and 'Twist-Free' washer before assembly of lug or wire.

GEMP

Great Eastern Metal Products Company

255 East Second Street, Mineola, New York 11501

Tel: (516) 747-0818 Fax: (516) 747-6724